

Mobility of Nitrogen-15-Labeled Nitrate and Sulfur-34-Labeled Sulfate during Snowmelt

John L. Campbell*

U.S. Forest Service
PO Box 640
Durham, NH 03824

Myron J. Mitchell

State Univ. of New York
College of Environmental Science and
Forestry
1 Forestry Dr.
Syracuse, NY 13210

Bernhard Mayer

Univ. of Calgary
2500 University Dr. NW
Calgary, AB
Canada T2N 1N4

Peter M. Groffman

Lynn M. Christenson

Institute of Ecosystem Studies
Box AB
Millbrook, NY 12545-0129

The objective of this study was to investigate the winter dynamics of SO_4^{2-} and NO_3^- in a forested soil to better understand controls on these acidifying anions during snowmelt. In February 2004, a stable isotopic tracer solution with 93 atom% ^{34}S as $\text{H}_2^{34}\text{SO}_4$ and 99 atom% ^{15}N as $\text{NH}_4^{15}\text{NO}_3$ was applied to the snowpack at the Hubbard Brook Experimental Forest in New Hampshire. The chemical and isotopic compositions of throughfall, snow, snowmelt, and forest floor leachates were monitored for 10 mo following the addition of the tracers. The $^{34}\text{SO}_4^{2-}$ and $^{15}\text{NO}_3^-$ tracer amounts in forest floor leachates were highest in the first fractions of meltwater and declined exponentially until returning to ambient levels in mid-May. Isotopic mass balances indicated that SO_4^{2-} and NO_3^- were conservative in the snowpack, with tracer recoveries near 100%. In contrast, only 54 to 62% of the $^{34}\text{SO}_4^{2-}$ and 49 to 58% of the $^{15}\text{NO}_3^-$ were recovered in forest floor leachates, suggesting that much of the SO_4^{2-} and NO_3^- that infiltrated the forest floor during snowmelt was retained or transformed. Microbial biomass $\delta^{15}\text{N}$ values in the forest floor remained low during snowmelt and the natural abundance values of $\delta^{18}\text{O}-\text{NO}_3^-$ in forest floor leachates were indicative of an atmospheric rather than a microbial source. These results suggest that, in this study, microbial immobilization and subsequent mineralization and nitrification of snowpack NO_3^- was insignificant in the forest floor during snowmelt.

Abbreviations: DNRA, dissimilatory nitrate reduction to ammonia; HBEF, Hubbard Brook Experimental Forest; PVC, polyvinyl chloride.

There has been much recent interest in understanding biogeochemical cycling in forest soils during winter. This interest stems from relatively recent findings that have shown that considerable microbial activity can occur in the forest floor and mineral soil beneath the snowpack at temperatures near freezing (Brooks et al., 1996; Monson et al., 2006; Schmidt and Lipson, 2004). While winter was once considered a period of dormancy, it is increasingly recognized as an important time for biogeochemical processes (Campbell et al., 2005). Despite the growing awareness of winter's critical role in nutrient cycling, many questions remain unanswered. In particular, there is much uncertainty about the extent and means by which nutrients are retained or transformed in forest soils during cold weather.

Sulfur and N cycling have been studied extensively in North America and Europe, largely because atmospheric deposition of

these elements has been elevated as a result of emissions due to the combustion of fossil fuels as well as other human activities. Stricter emissions regulations have led to a reduction of S deposition since 1975 in the United States, yet N deposition remains high (Driscoll et al., 2001; Kahl et al., 2004). In forests of the northeastern United States, SO_4^{2-} and NO_3^- are, respectively, the dominant forms of S and N in precipitation, throughfall, soil water, and surface waters. Atmospheric SO_4^{2-} and NO_3^- inputs accumulate in the snowpack during the winter and are transferred in a relatively short period during snowmelt. For example, half of the water exported annually at the Hubbard Brook Experimental Forest (HBEF) in the White Mountains of New Hampshire occurs during the months of March through May, which includes snowmelt (Bailey et al., 2003). During this same time period, approximately 52% of annual SO_4^{2-} and 68% of annual NO_3^- are exported in stream water (Likens and Bormann, 1995). The pulsed release of SO_4^{2-} and NO_3^- during snowmelt commonly causes episodic acidification in poorly buffered ecosystems, resulting in short-term decreases in acid-neutralizing capacity and pH (Wigington et al., 1996).

Both SO_4^{2-} and NO_3^- are thought to be conservative during winter when biological assimilation is minimal. Microbial activity has been detected in soils at temperatures near and below 0°C (Schadt et al., 2003; Sommerfeld et al., 1993), however, and there is increasing evidence that indicates strong biotic retention of SO_4^{2-} and NO_3^- in forest soil beneath the snowpack (Houle et al., 2004; Judd et al., 2007; Preston et al., 1990). Evidence of subnival heterotrophic activity is further corroborated by studies that have used the

Soil Sci. Soc. Am. J. 71:1934–1944

doi:10.2136/sssaj2006.0283

Received 14 Aug. 2006.

*Corresponding author (jlcampbell@fs.fed.us).

© Soil Science Society of America

677 S. Segoe Rd. Madison WI 53711 USA

All rights reserved. No part of this periodical may be reproduced or transmitted in any form or by any means, electronic or mechanical, including photocopying, recording, or any information storage and retrieval system, without permission in writing from the publisher.

Permission for printing and for reprinting the material contained herein has been obtained by the publisher.

natural abundance of stable isotopes to identify sources of stream water SO_4^{2-} and NO_3^- . The isotopic changes in N and S solutes that occur in the forest floor and upper mineral soil, even during winter, indicate that a large proportion of SO_4^{2-} and NO_3^- passes through the microbial pool before being exported to drainage waters (Campbell et al., 2006; Kendall et al., 1996; Mayer et al., 1995; Pardo et al., 2004; Piatek et al., 2005; Shanley et al., 2005).

In addition to biological controls on SO_4^{2-} and NO_3^- , abiotic processes may also regulate the export of these anions. Abiotic retention of SO_4^{2-} has long been recognized as an important process; some reactions, such as adsorption–desorption, have been studied in detail while other reactions are chemically complex and are still not fully understood (see Mitchell et al., 1992). The two abiotic SO_4^{2-} retention mechanisms that have been studied most extensively are SO_4^{2-} mineral formation and especially SO_4^{2-} adsorption. The former has been suggested to occur when pH is low and Al concentrations are high, resulting in precipitation of aluminum sulfate minerals. The latter occurs by a variety of mechanisms including when SO_4^{2-} displaces OH^- on Al and Fe hydroxides. Sulfate adsorption can be important in forest soils and can explain spatial and temporal patterns of SO_4^{2-} retention (e.g., Johnson and Mitchell, 1998). Far less is known about abiotic retention of NO_3^- ; however, several studies have suggested that this may be an important process affecting ecosystem N retention (Dail et al., 2001; Davidson et al., 2003; Fitzhugh et al., 2003).

Few studies have used isotopic labeling techniques to gain an understanding of winter processing of NO_3^- and SO_4^{2-} in forested ecosystems and none have simultaneously applied isotopically enriched NO_3^- and SO_4^{2-} tracers. There have been no previous snowpack $^{34}\text{SO}_4^{2-}$ isotope tracer additions, mainly because the limited availability and exorbitant cost of highly enriched $^{34}\text{SO}_4^{2-}$ has precluded its use in field applications. In one experiment, radiogenic $^{35}\text{SO}_4^{2-}$ was applied to the snowpack in a boreal coniferous forest in Quebec, Canada (Houle et al., 2004). Results indicated strong retention and transformation of SO_4^{2-} in soils during winter. Snowpack additions of isotopically labeled NO_3^- are also rare, and past studies have generally used isotopic tracers combined with N fertilization. Williams et al. (1996) applied $^{15}\text{NO}_3^-$ and $^{15}\text{NH}_4^+$ to snow at an alpine site in Colorado and found no transformation of N within the snowpack. In an N fertilizer experiment in British Columbia, Canada, Preston et al. (1990) applied 100 kg N ha^{-1} as $^{15}\text{NO}_3^-$ to the snowpack of an 11-yr-old lodgepole pine (*Pinus contorta* Dougl. var. *latifolia* Engelm.) forest. After one growing season, 40% of the labeled N was recovered in soils, indicating that some of the NO_3^- was retained.

The purpose of our study was to examine the mobility of NO_3^- and SO_4^{2-} deposited in snow in a northern hardwood forest ecosystem exposed to levels of N and S deposition that are considered high ($5.3 \text{ kg N ha}^{-1} \text{ yr}^{-1}$ and $5.6 \text{ kg S ha}^{-1} \text{ yr}^{-1}$) for North America. Isotopically labeled N and S were applied simultaneously to the snowpack in February at the HBEF to investigate retention and transformation of NO_3^- and SO_4^{2-} during spring snowmelt, and LiBr was applied as a biologically inert hydrologic tracer. We designed our study as a tracer experiment, whereby the addition of $\text{NH}_4\text{NO}_3\text{-N}$ and $\text{H}_2\text{SO}_4\text{-S}$ was negligible ($1.7 \text{ g N ha}^{-1} \text{ yr}^{-1}$ and $1.8 \text{ g S ha}^{-1} \text{ yr}^{-1}$) compared with annual ambient N and S deposition. The use of highly enriched stable isotopic tracers (99 atom% ^{15}N and 93 atom% ^{34}S) enabled us to apply extremely small quan-

ties of N and S, comparable to the amount deposited in a dusting of natural snowfall ($\sim 0.2\text{-mm}$ water equivalent). Thus, background concentrations of NO_3^- , NH_4^+ , H^+ , and SO_4^{2-} were minimally altered as a result of the tracer addition. Tracers were confined to the area above the lysimeters and water fluxes were measured, rather than modeled, resulting in more accurate and sensitive measurements of tracer recovery. The goals of this research were to: (i) determine the extent to which atmospherically deposited NO_3^- and SO_4^{2-} are transformed in the snowpack; (ii) quantify how much snowpack NO_3^- and SO_4^{2-} is retained or transformed in the forest floor during snowmelt; and (iii) determine the importance of microbial immobilization of snowpack NO_3^- that infiltrates the forest floor. To accomplish these goals, we quantified concentrations, fluxes, and isotopic compositions of NO_3^- and SO_4^{2-} in throughfall, snow, snowmelt, and forest floor leachates for 10 mo following the addition of the isotopic tracers. Additionally, we assessed the importance of microbial NO_3^- immobilization by tracing the labeled $^{15}\text{NO}_3^-$ into the forest floor microbial biomass N pool.

MATERIALS AND METHODS

Site Description

This research was conducted at the HBEF in the White Mountain National Forest, New Hampshire. The study site is on a south-facing slope east of Norris Brook ($43^\circ 56' 52'' \text{ N}$, $71^\circ 42' 14'' \text{ W}$) at an elevation of 270 m. The climate is humid continental, with average maximum daily air temperatures ranging from 26°C in July to -3°C in January (Bailey et al., 2003). Twenty-seven-year average annual precipitation at the study site is 1210 mm, with 30% falling as snow. The winter snowpack is typically continuous, with a mean maximum depth of 490 mm (12-yr mean). The long-term (12-yr) mean maximum frost depth is 73 mm, and soil frost is present during winter approximately 3 out of 4 yr, depending on the depth and timing of snowfall. The forest is classified as northern hardwood and was cut heavily from 1910 to 1917. In the 1950s, selective cutting resulted in an uneven-aged forest, dominated by American beech (*Fagus grandifolia* Ehrh.), sugar maple (*Acer saccharum* Marsh.), and yellow birch (*Betula alleghaniensis* Britt.). Soils are acidic Spodosols (Haplorthods) with a thick (10-cm), organic forest floor layer at the surface. The soils have a sandy loamy texture and are well drained and shallow, with bedrock occurring at a depth of 1 m.

Field Equipment and Sampling

A total of eight 5- by 5-m plots were selected randomly at the study site. Forest floor and snow lysimeters were installed in the center of four of the plots, and the remaining four plots were designated for destructive snow and soil sampling. Forest floor lysimeters were installed 8 mo before the isotope addition to ensure that there was sufficient time for the soil to equilibrate after installation disturbance. The lysimeters were constructed of heavy-duty (6-mm) polyvinyl chloride (PVC), and were large enough (1.064 m^2) to allow frequent sampling and also to provide adequate water volume for isotopic analyses (Fig. 1). The forest floor was excavated to the top of the mineral soil, and this intact excavated layer was placed in the forest floor lysimeter. The lysimeter was installed in the soil at a depth of 10 cm, which was consistent with the depth of the forest floor it contained. Snow lysimeters were placed directly on the surface of the forest floor to capture meltwater from the bottom of the snowpack. Snow and forest floor lysimeters were angled slightly so that leachates drained by gravity through a PVC pipe to an underground storage container. The storage container was accessible through the surface of the snow and was insulated to prevent the drainage water from freezing. Three of the storage containers housed 20-L

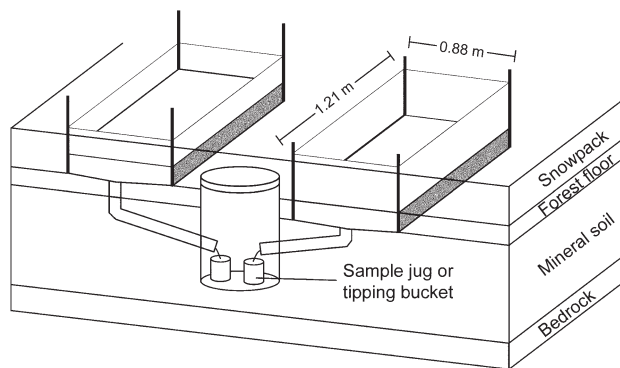

Fig. 1. Schematic diagram of snowmelt and forest floor lysimeters.

polyethylene jugs for collecting water samples. A fourth storage container housed tipping buckets for measuring water volume. Tipping buckets were connected to a datalogger that measured snowmelt and forest floor leachate volumes at 15-min intervals during the study. Water samples were collected on an individual snowmelt event basis and were stored in the dark underground at cool temperatures. Water samples from each of the snow and forest floor lysimeters were transferred from the 20-L collection containers to 250-mL bottles for ionic analyses (i.e., concentrations of SO_4^{2-} , NO_3^- , and NH_4^+). Samples for isotopic analyses consisted of a composite of equal amounts of water from each of the three snow and forest floor lysimeters.

Destructive sampling of snow and soil was conducted at separate plots so that the lysimeters remained undisturbed. Sampling areas, identical to the lysimeters in size and shape, were marked by vertical stakes in the autumn of 2003 before the snowpack developed. Snow samples for isotopic analyses were collected on four occasions by removing all the snow with an acid-washed, high-density polyethylene shovel in the 1-m² areas that received the tracer application. Snow samples for measuring concentrations of NO_3^- , SO_4^{2-} , and NH_4^+ in the snowpack were collected more frequently (2-wk intervals) using an acid-washed, beveled PVC tube. A sample consisted of multiple vertical cores, depending on the depth of snow, of the entire snowpack. All snow samples were placed in polyethylene bags and were transported to the laboratory on the same day of collection.

Soil samples were collected on three occasions: before the isotope addition (18 Feb. 2004), during peak snowmelt (4 Mar. 2004), and during the summer after the isotope addition (12 July 2004). In February and March 2004, soil samples were collected from the same location where the snow sample was removed. On each sampling date, three cores of the forest floor were collected using a 6-cm-diameter stainless steel soil corer. The three samples were placed in separate plastic bags and were immediately transported to a laboratory at the HBEF.

Throughfall was collected biweekly during the snow-covered period (6 Dec. 2003–3 Mar. 2004) at six randomly selected plots. Throughfall snow collectors for water volume and ionic analyses consisted of 15-cm-diameter by 50-cm-long PVC pipes lined with polyethylene collection bags. The collectors were mounted on vertical stakes 1.5 m above the ground surface. Since the isotopic analyses required a large sample volume, six 40-L polyethylene containers were co-located with throughfall collectors. Throughfall samples for isotopic analyses consisted of a composite sample from these collectors. Throughfall samples were transported immediately to the laboratory in collection bags for further processing.

Snow depth and snow water equivalence were measured adjacent to the site on a weekly basis as part of the long-term sampling program at HBEF. A Mt. Rose snow tube was used to core and weigh the snow at 10 sampling points along a transect. Soil frost was measured biweekly at the six throughfall collector locations using soil frost gauges (Ricard et al.,

1976). Soil temperature thermistors were installed at six depths (1, 3, 7, 15, 30, and 50 cm) in two locations. Soil temperature probes were connected to a datalogger and recorded temperatures at 15-min intervals. Air temperature also was measured at 15-min intervals at one location.

Tracer Application

A tracer solution was applied to the surface of the snowpack above each lysimeter on 18 Feb. 2004, when snowpack depth and water equivalence were near maximum values for the winter (285 and 36 mm, respectively). The tracer consisted of 93 atom% ^{34}S applied as $\text{H}_2^{34}\text{SO}_4$ and 99 atom% ^{15}N applied as $\text{NH}_4^{15}\text{NO}_3$. The quantity of the isotopic tracers applied to the snowpack ($91 \mu\text{g } ^{15}\text{N m}^{-2}$ and $182 \mu\text{g } ^{34}\text{S m}^{-2}$) was calculated to increase the isotopic composition of the snowpack significantly above natural abundance levels without exceeding the analytical constraints of the laboratory (1000‰ for $\delta^{15}\text{N}$ and 200‰ for $\delta^{34}\text{S}$). In addition to isotopic tracers, $152 \text{ mg Br}^- \text{ m}^{-2}$ was added (as LiBr) as a conservative chemical tracer. The dilute solution (mixed with 500 mL of distilled, deionized water) was applied uniformly to the snowpack above each lysimeter using a hand-pump sprayer. The tracer solution also was applied to areas designated for destructive snow and soil sampling. Since lateral water movement through snow and soil can hamper tracer recovery (e.g., Houle et al., 2004; Williams et al., 1996), an effort was made to contain the water and tracers within the application area. Vertical stakes and plastic sheeting were used to create a boundary around the perimeters of the lysimeters and soil sampling areas. Sheeting was added and removed as snow depth changed to maintain a snow depth within the application area that was consistent with the surrounding area.

Laboratory Procedures for Aqueous Samples

All aqueous samples were transported to the analytical laboratory at the USDA Forest Service, Northern Research Station, Durham, NH, on the day they were collected. Throughfall and snowpack samples were melted in polyethylene containers at room temperature immediately after returning to the laboratory. Throughfall water volumes were measured and samples for ionic analyses were transferred into 250-mL bottles and stored in the dark at 2°C until analysis. Measurements of SO_4^{2-} , NO_3^- , NH_4^+ , and Br^- concentrations were made using ion chromatography with an inline cellulose membrane filter (0.15- μm pore size), usually within 2 d of collection. Samples for isotopic analyses were filtered through 0.45- μm high-capacity filter capsules and were acidified to pH 3 with dilute HCl to remove HCO_3^- . Appropriate sample volumes then were passed through anion exchange resin columns (Bio-Rad AG 1-X8) to retain and store the amount of NO_3^- -N and SO_4^{2-} -S necessary for analysis (1 mg NO_3^- -N and 1 mg SO_4^{2-} -S). Resin columns were shipped immediately to the Isotope Science Laboratory at the University of Calgary, AB, Canada.

The procedures for the determination of N and O isotope ratios of NO_3^- and S isotope ratios of SO_4^{2-} are based on methods described by Silva et al. (2000) and Giesemann et al. (1994), respectively. In short, NO_3^- and SO_4^{2-} were eluted from anion exchange resins with 15 mL of 3 mol L⁻¹ HCl solution. One mL of 0.2 mol L⁻¹ BaCl_2 solution was added to the eluant to precipitate SO_4^{2-} as BaSO_4 , which subsequently was isolated on a 0.45- μm membrane filter. After removing excess Ba^{2+} in a cation exchange column (Bio-Rad AG 50W-X8, Bio-Rad Laboratories, Hercules, CA), the remaining eluant solution containing HNO_3 and HCl was neutralized by adding Ag_2O . The reaction causes AgCl to precipitate, leaving Ag^+ and NO_3^- in solution after removal of AgCl by filtration. The solution was freeze-dried to yield pure AgNO_3 . In addition to these isotopic analyses, a small subset (five samples) of forest floor leachate samples also was analyzed for $^{15}\text{N}/^{14}\text{N}$ of NH_4^+ at the University of Calgary. The purpose

of this analysis was to determine if any of the labeled NO_3^- was reduced to NH_4^+ in the forest floor. One pretreatment and four post-treatment forest floor leachate samples were selected for this analysis. An NH_4^+ diffusion method with a small sample volume requirement (50–150 μg of dissolved NH_4^+ -N) was used (Sebilo et al., 2004). Ammonium was volatilized to NH_3 by adjusting the pH with NaOH. The released NH_3 was trapped on an acidified (with H_2SO_4) glass fiber filter yielding $(\text{NH}_4)_2\text{SO}_4$.

The AgNO_3 and the freeze-dried glass fiber filters were converted to N_2 by high-temperature reaction in an elemental analyzer and $^{15}\text{N}/^{14}\text{N}$ ratios were determined using an isotope ratio mass spectrometer in continuous-flow mode (CF-IRMS). For O isotopic analyses of NO_3^- , AgNO_3 -O was converted to CO at 1350°C in a pyrolysis reactor, and $^{18}\text{O}/^{16}\text{O}$ ratios of the gas were measured by CF-IRMS. Sulfur as BaSO_4 was converted to SO_2 in an elemental analyzer and $^{34}\text{S}/^{32}\text{S}$ ratios were determined by CF-IRMS. Nitrogen, S, and O isotope ratios are expressed in the typical delta notation in per mil (‰):

$$\delta(\text{‰}) = [(R_{\text{sample}}/R_{\text{standard}}) - 1]10^3 \quad [1]$$

where R_{sample} and R_{standard} are the $^{34}\text{S}/^{32}\text{S}$, $^{15}\text{N}/^{14}\text{N}$, or $^{18}\text{O}/^{16}\text{O}$ ratio of the sample and the standard, respectively. The internationally accepted standards are: Vienna-Canyon Diablo troilite for S isotopes, AIR for N isotopes, and Vienna standard mean ocean water for O isotopes. The analytical uncertainty, including extraction, gas preparation, and isotope measurement, was $\pm 0.5\text{‰}$ for $\delta^{34}\text{S}$ - SO_4^{2-} , $\delta^{15}\text{N}$ - NO_3^- , and $\delta^{18}\text{O}$ - NO_3^- measurements.

Laboratory Procedures for Soil Samples

In the laboratory at the HBEF, sticks, roots, and stones were removed from soil samples by hand. A subsample of soil was used for determination of potential N mineralization and nitrification following the procedure described by Robertson et al. (1999). Samples were placed in airtight glass jars and were incubated in the dark at 25°C for 10 d. Ammonium and NO_3^- were extracted from initial and incubated soil samples using 2 mol L^{-1} KCl. The extract solutions were transported to the laboratory at the Institute of Ecosystem Studies, Millbrook, NY, where they were analyzed for NH_4^+ and NO_3^- concentrations using a continuous flow colorimeter (salicylate and Cd reduction methods, respectively). Net N mineralization was calculated as the accumulation of total inorganic N (NH_4^+ and NO_3^-) during the incubation. Net nitrification was calculated as the accumulation of NO_3^- only. Potential net N mineralization and nitrification values are reported in milligrams N per kilogram dry soil per day.

Microbial biomass N contents were measured using the chloroform-fumigation incubation method (Paul et al., 1999). Soil subsamples were fumigated with chloroform to kill and lyse any living cells. The fumigated samples subsequently were inoculated with fresh soil and sealed in an airtight jar for 10 d at 25°C. Microorganisms from the inoculated soil grow vigorously, using the dead cells as a substrate. The inorganic N produced during the incubation was assumed to be proportional to the amount of N in the microbial biomass of the original samples. Inorganic N was determined by KCl extraction followed by measurement on a continuous flow colorimeter, as described above.

A N diffusion technique (modified from Brooks et al., 1989) was used to determine soil KCl-extractable $^{15}\text{N}/^{14}\text{N}$ and microbial biomass $^{15}\text{N}/^{14}\text{N}$ ratios. The procedure is similar to that described above for $\delta^{15}\text{N}$ - NH_4^+ -N analyses. Briefly, NO_3^- was reduced to NH_4^+ with Devarda's alloy, and MgO was added to raise the pH. The volatilized NH_3 then was captured on acidified filter disks. The disks were sent to the stable isotope laboratory at the University of California at Davis for N isotope analyses using a

CF-IRMS with on-line combustion. Nitrogen diffusion recoveries on the acidified filter disks were $>95\%$. Measurement precision reported by the University of California at Davis is less than $\pm 0.2\text{‰}$ for all $\delta^{15}\text{N}$ values.

Mass Balances

Fluxes of measured ions (SO_4^{2-} , NO_3^- , NH_4^+ , and Br^-) in throughfall, snowmelt, and forest floor leachates were calculated by multiplying the concentrations of ions by the actual water volume measured during a sampling period. Fluxes of solutes for the snow-covered period were calculated by summing values for each sampling period from 6 Dec. 2003 through 22 Mar. 2004. For snowmelt and forest floor leachates, the $^{15}\text{N}/^{14}\text{N}$ and $^{34}\text{S}/^{32}\text{S}$ ratios of NO_3^- and SO_4^{2-} were used to estimate the export of the isotopic tracers with the NO_3^- and SO_4^{2-} fluxes. Isotopic tracer recovery in pools (i.e., snowmelt or forest floor leachates) was expressed as a proportion of the total tracer applied to the lysimeters:

$$\%X_{\text{recovered}} = \frac{m_{\text{pool}}(\text{atom}\% X_{\text{pool}} - \text{atom}\% X_{\text{bgnd}})}{m_{\text{applied}} \text{atom}\% X_{\text{applied}}} \quad [2]$$

where X is ^{34}S or ^{15}N , m_{pool} is the mass of SO_4^{2-} -S or NO_3^- -N in the ecosystem pool (mg m^{-2}), $\text{atom}\% X_{\text{pool}}$ is the ^{34}S or ^{15}N in the ecosystem pool, $\text{atom}\% X_{\text{bgnd}}$ is the background ^{34}S or ^{15}N in the ecosystem pool, m_{applied} is the mass of SO_4^{2-} -S or NO_3^- -N applied, and $\text{atom}\% X_{\text{applied}}$ is the ^{34}S or ^{15}N of the applied tracer. Recovery of ^{34}S and ^{15}N in the forest floor leachates is expressed as a range. The upper value assumes that none of the tracer was lost by leakage, whereas the lower range assumes a 17% loss based on the Br^- recovery results.

Statistical Analyses

An analysis of variance was conducted to determine if there were significant differences ($\alpha = 0.05$) among throughfall, snowmelt, and forest floor leachate concentrations for each ion investigated (SO_4^{2-} -S, NH_4^+ -N, and NO_3^- -N). Where significant variations existed, pairwise comparisons for post hoc determination of significant differences between means were made using a Tukey-Kramer test. Snowpack samples consisted of a composite sample collected at each sampling interval. Therefore, replicate snowpack samples were not collected, and we could not determine if the snowpack concentrations were significantly lower than other concentrations. Analysis of variance was applied also to flux data to determine if there were significant differences among throughfall, snowmelt, and forest floor leachate fluxes for SO_4^{2-} -S, NH_4^+ -N, and NO_3^- -N.

RESULTS

Water and Nutrient Fluxes

There was continuous snow cover from 6 December through 22 March during the winter of 2003–2004. Approximately 270 mm of precipitation fell during the snow-covered period, which was 20% of the annual precipitation of the 2003–2004 water year (based on a 1 June–31 May water year). Due to unusually low snowfall, the snowpack during the study winter had the lowest maximum water equivalent (36 mm) measured within the long-term record from 1993 to 2005, about 30% of the 13-yr mean maximum snow water equivalent (123 mm). No measurable snowmelt occurred for 10 d following the tracer application because of cold air temperatures (Fig. 2). The major spring snowmelt event began on 29 Feb. 2004 and ended on 22 Mar. 2004. A rain-on-snow event occurred on 4 Mar. 2004, which caused significant melting and infiltration, resulting in a marked increase in snow and forest floor leachate water volume shortly thereafter.

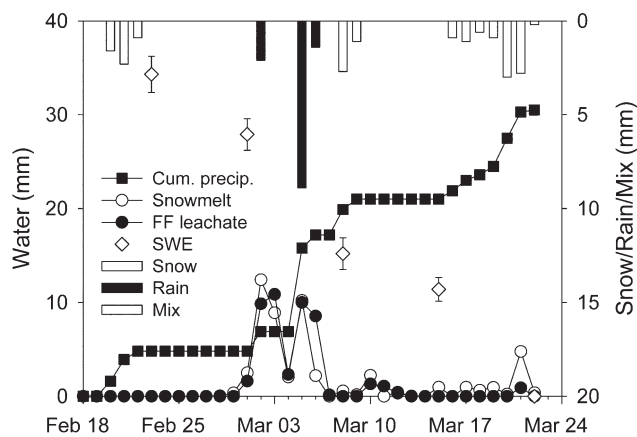

Fig. 2. Daily cumulative precipitation, snowmelt, forest floor (FF) leachate and weekly snowpack water equivalent (SWE) (\pm standard error) for the period from when the chemical and isotopic tracers were applied (18 Feb. 2004) to the end of the snowmelt (22 Mar. 2004). Vertical bars indicate the daily quantity of precipitation (snow, rain, or snow-rain mix) at the study site with the scale shown on the secondary y axis.

Concentrations of $\text{SO}_4^{2-}\text{-S}$ and $\text{NH}_4^+\text{-N}$ increased significantly as water moved from throughfall to forest floor leachates (Table 1). The concentration of $\text{NO}_3^-\text{-N}$ tended to be lower in forest floor leachates than snowmelt and throughfall, but these differences were not statistically significant. Fluxes of $\text{SO}_4^{2-}\text{-S}$ were not significantly different among throughfall, snowmelt, and forest floor leachates, and ranged from 0.85 to 1.06 kg ha^{-1} during the period of snow cover (6 Dec. 2003–22 Mar. 2004; Fig. 3). During this same period, the flux of $\text{NH}_4^+\text{-N}$ in the forest floor leachate (1.6 kg N ha^{-1}) was approximately four times higher than throughfall and snowmelt fluxes. In contrast, the flux of $\text{NO}_3^-\text{-N}$ from the forest floor (0.5 kg N ha^{-1}) was significantly lower than throughfall and snowmelt fluxes.

Soil Characteristics and Processes

The low snow accumulation during the study winter resulted in low soil temperatures and deeper-than-average soil frost (Fig. 4). Temperatures at the 7-cm depth or less were $<0^\circ\text{C}$ for 52 (7-cm depth) to 62 (1-cm depth) nonconsecutive days during the winter, whereas temperatures at depths of 15 cm and greater consistently remained $>0^\circ\text{C}$. These soil temperature results were in general agreement with soil frost gauge measurements (Fig.

4). Soil frost reached a maximum depth of 8 cm near the end of January (slightly above the long-term mean of 7.3 cm measured from 1994–2005; U.S. Forest Service, unpublished data, 2007, www.hubbardbrook.org/data/dataset.php?id=63) and declined during the remainder of the snow-covered period.

Microbial biomass N in the forest floor ranged from 354 to 400 mg N kg^{-1} dry soil and showed no significant temporal variability (Table 2). Relatively high potential net N mineralization rates were found in the forest floor. In contrast, potential net nitrification was near zero. Forest floor extractable $\text{NH}_4^+\text{-N}$ greatly exceeded extractable $\text{NO}_3^-\text{-N}$ on all sampling dates (Table 2), and comprised nearly all ($>95\%$) of the extractable dissolved inorganic N ($\text{NH}_4^+\text{-N} + \text{NO}_3^-\text{-N}$). Concentrations of extractable $\text{NH}_4^+\text{-N}$ were highly variable and showed no significant differences among sampling dates; however, mean $\text{NH}_4^+\text{-N}$ concentrations were markedly higher during the sampling date in July than in February or March. Concentrations of extractable $\text{NO}_3^-\text{-N}$ were significantly lower during the summer sampling date (ANOVA, $P = 0.004$).

Tracer Recovery

Background (pretreatment) $\delta^{34}\text{S}\text{-SO}_4^{2-}$ and $\delta^{15}\text{N}\text{-NO}_3^-$ values in throughfall, snow, snowmelt, and soil water showed little variability, ranging between 4.9 and 5.4‰ ($\delta^{34}\text{S}\text{-SO}_4^{2-}$) and -3.1 and 1.3‰ ($\delta^{15}\text{N}\text{-NO}_3^-$). Concentrations of Br^- before the treatment were $<0.08 \text{ mg L}^{-1}$ in all measured pools, which was slightly above the detection limit (0.02 mg L^{-1}). The tracer was applied on 18 Feb. 2004, when the snowpack water equivalence was at its maximum value for the winter (36 mm). The highest chemical tracer (Br^-) concentrations were found in the initial meltwaters, 10 d after tracer application (Fig. 5d). Maximum snowmelt $\delta^{34}\text{S}\text{-SO}_4^{2-}$ and $\delta^{15}\text{N}\text{-NO}_3^-$ values (142 and 888‰, respectively) were near target application values (200 and 1000‰, respectively) and these measured values far exceeded the $\delta^{34}\text{S}$ and $\delta^{15}\text{N}$ values of pretracer SO_4^{2-} and NO_3^- . In snowmelt and forest floor leachates, the isotopic tracer ($\delta^{34}\text{S}$ and $\delta^{15}\text{N}$) values followed an exponential decline (where x is the day fraction following the initial sample collection):

$$\delta^{15}\text{N}_{\text{snowmelt}} = 7.4\exp[13.7/(x + 2.9)]$$

$$R^2 = 0.999, P = 0.037$$

$$\delta^{34}\text{S}_{\text{snowmelt}} = 1.1\exp[18.1/(x + 3.7)]$$

$$R^2 = 0.999, P = 0.022$$

$$\delta^{15}\text{N}_{\text{forest floor leachates}} = 6.7\exp[36.0/(x + 7.9)],$$

$$R^2 = 0.998, P < 0.001$$

$$\delta^{34}\text{S}_{\text{forest floor leachates}} = 6.0\exp[9.5/(x + 3.8)],$$

$$R^2 = 0.997, P = 0.002$$

Table 1. Water flux and mean concentrations of $\text{SO}_4^{2-}\text{-S}$, $\text{NH}_4^+\text{-N}$, and $\text{NO}_3^-\text{-N}$ in throughfall, snowpack, snowmelt, and forest floor leachates, during the snow-covered period (6 Dec. 2003–22 Mar. 2004).

Pool	Water flux	$\text{SO}_4^{2-}\text{-S}$	$\text{NH}_4^+\text{-N}$	$\text{NO}_3^-\text{-N}$
	mm	mg L^{-1}		
Throughfall	217	0.73 (0.07) a†	0.27 (0.06) a	0.69 (0.06) a
Snowpack	–	0.14	0.07	0.25
Snowmelt	136	1.03 (0.10) ab	0.32 (0.08) a	0.88 (0.09) a
Forest floor leachates	131	1.20 (0.10) b	1.35 (0.08) b	0.54 (0.09) a

† For each ion, different lowercase letters indicate significant differences among throughfall, snowmelt, and forest floor leachate concentrations ($\alpha = 0.05$). Numbers in parentheses are standard errors of the group means. Water flux and snowpack samples were omitted from the ANOVA because replicate measurements were not made.

The isotopic tracer declined more precipitously in snowmelt than in forest floor leachates. The temporal trend for the Br^- tracer was generally similar to that of $\delta^{34}\text{S}\text{-SO}_4^{2-}$ and $\delta^{15}\text{N}\text{-NO}_3^-$ values, but there was a slight increase in Br^- concentrations in forest floor leachates during sampling dates in mid-April and mid-May (Fig. 5d). We continued to track the tracer in forest floor leachates for 10 mo following the addition. The isotopic values returned to pretreatment levels by 11 May 2004 (53 d after the

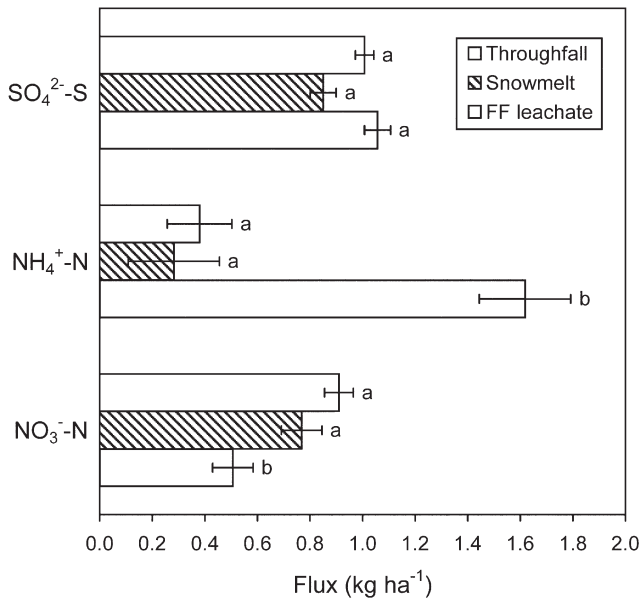

Fig. 3. Fluxes of $\text{SO}_4^{2-}\text{-S}$, $\text{NH}_4^+\text{-N}$, and $\text{NO}_3^-\text{-N}$ in throughfall, snowmelt, and forest floor (FF) leachates for the snow-covered period (6 Dec. 2003–22 Mar. 2004). For each ion, different lowercase letters indicate significant differences among throughfall, snowmelt, and forest floor leachate fluxes ($\alpha = 0.05$). Error bars indicate the standard error of the group means.

tracer was applied) and remained low (less than 5.4‰ $\delta^{34}\text{S}\text{-SO}_4^{2-}$ and -1.1‰ $\delta^{15}\text{N}\text{-NO}_3^-$) through December 2004 when monitoring was terminated. The $\delta^{15}\text{N}\text{-NH}_4^+\text{-N}$ values in the forest floor leachates remained at background levels (1.6–3.3‰) following the tracer addition, indicating that the labeled ^{15}N in NO_3^- was not transformed into NH_4^+ in the forest floor (Fig. 5c). Recovery of the $^{15}\text{N}\text{-NO}_3^-$ tracer in snowmelt was excellent (100%), with slightly lower recovery for $^{34}\text{S}\text{-SO}_4^{2-}$ (90%) and Br^- (89%) (Table 3). The recovery of the chemical Br^- tracer in forest floor leachates was 6% lower than its recovery in snowmelt. By contrast, a smaller fraction of the $^{15}\text{N}\text{-NO}_3^-$ and $^{34}\text{S}\text{-SO}_4^{2-}$ (49–58 and 54–62%, respectively) added to the snowpack surface was recovered in the forest floor leachates.

Natural abundance $\delta^{18}\text{O}\text{-NO}_3^-$ values of atmospheric NO_3^- (throughfall, snowpack, and snowmelt) ranged from 66.2 to 87.7‰ (Fig. 5e). The range in $\delta^{18}\text{O}\text{-NO}_3^-$ values of the forest floor leachates showed a strong seasonal pattern, with markedly higher values during the snow-covered period (58.9–87.4‰ for January–March) compared with the snow-free period (3.3–25.3‰ for April–December).

Analysis of variance results indicate that $\delta^{15}\text{N}$ values of KCl-extractable NO_3^- increased following the isotopic addition (Fig. 6) and were significantly higher in July than at the pretreatment sampling date. Microbial biomass $\delta^{15}\text{N}$ was also significantly higher in July than either the pretreatment or March sampling dates.

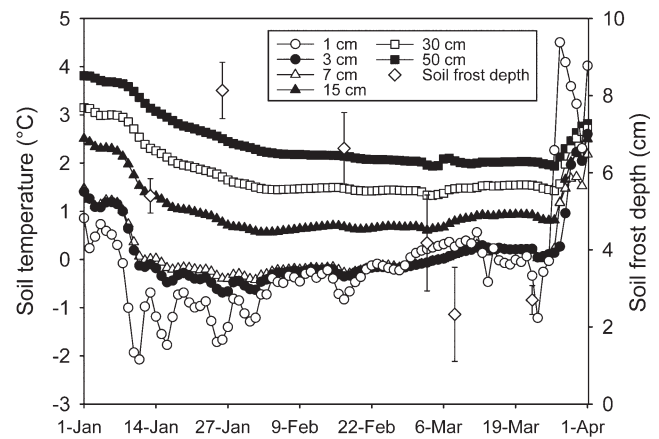

Fig. 4. Mean daily soil temperature (primary y axis) at six depths (1, 3, 7, 15, 30, and 50 cm) and soil frost depth (secondary y axis) measured from January to April 2004. Error bars for soil frost indicate standard errors of the means.

DISCUSSION

By the time the snowpack fully melted, nearly all of the applied $^{34}\text{SO}_4^{2-}$ and $^{15}\text{NO}_3^-$ had been recovered in meltwater, indicating that SO_4^{2-} and NO_3^- in the snowpack were conservative and were not transformed to other forms of N and S. Biological reactions can contribute to transformations of snowpack NO_3^- , and some studies in the northeastern United States have indicated N cycling within the snowpack before melting (Burns and Kendall, 2002; Schaefer and Driscoll, 1993). Similarly, studies in polar regions have shown that NO_3^- within the snowpack can be depleted by photolysis (Blunier et al., 2005; Hastings et al., 2004). Our results for NO_3^- are similar to the findings of Williams et al. (1996), who reported no significant transformations of NO_3^- in snow following a $\text{K}^{15}\text{NO}_3^-$ addition to an alpine snowpack at Niwot Ridge, CO. Compared to NO_3^- , far less is known about SO_4^{2-} transformations within the snowpack. While there are no similar isotopic tracer studies of snowpack SO_4^{2-} , isotopic natural abundance isotope ratios indicate little transformation of SO_4^{2-} within the snowpack (Campbell et al., 2006).

In contrast to our snowpack results, recovery of labeled $^{34}\text{SO}_4^{2-}$ and $^{15}\text{NO}_3^-$ in forest floor leachates was much lower. Only about 54 to 62% of the $^{34}\text{SO}_4^{2-}$ and 49 to 58% of the $^{15}\text{NO}_3^-$ applied to the snow surface was recovered in the forest floor lysimeters. Based on isotopic mass balances, these data suggest that some of the SO_4^{2-} and NO_3^- that infiltrated the forest floor during snowmelt

Table 2. Summary of selected soil properties measured in the forest floor. Values are means ($n = 3$) taken on three sampling dates: before the tracer addition (18 Feb. 2004), during snowmelt (4 Mar. 2004), and midsummer (12 July 2004). Numbers in parentheses are standard errors of the means.

Soil property	18 Feb. 2004	4 Mar. 2004	12 July 2004
Microbial N, mg N kg^{-1} soil	400 (17)	354 (19)	389 (127)
Potential net N mineralization, mg N kg^{-1} dry soil d^{-1}	4.4 (0.4)	1.0 (0.4)	3.3 (1.1)
Potential net nitrification, mg N kg^{-1} dry soil d^{-1}	-0.01 (0.01)	<0.01 (0.01)	<0.01 (<0.01)
Soil $\text{NH}_4^+\text{-N}$, mg N kg^{-1} dry soil	19.6 (3)	23.1 (2)	120.0 (65)
Soil $\text{NO}_3^-\text{-N}$, mg N kg^{-1} dry soil	1.0 (0.07)	0.8 (0.02)	0.5 (0.07)

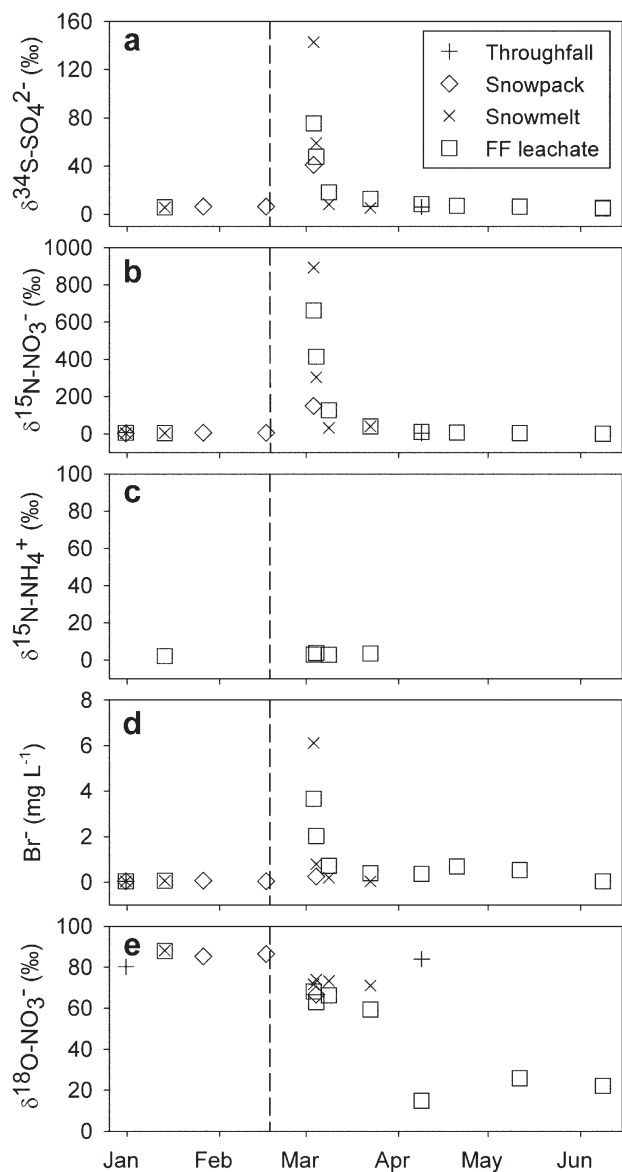

Fig. 5. Isotopic [(a) $\delta^{34}\text{S-SO}_4^{2-}$, (b) $\delta^{15}\text{N-NO}_3^-$, (c) $\delta^{15}\text{N-NH}_4^+$, and (e) $\delta^{18}\text{O-NO}_3^-$] and (d) Br^- values measured in throughfall, snowpack, snowmelt, and forest floor (FF) leachates from 31 Dec. 2003 to 8 June 2004. The dashed line indicates the date of the tracer application (18 Feb. 2004), which consisted of enriched $\delta^{34}\text{S-SO}_4^{2-}$, $\delta^{15}\text{N-NO}_3^-$, and Br^- .

was retained or transformed. Houle et al. (2004) measured SO_4^{2-} retention during snowmelt in a boreal coniferous forest in Quebec, Canada, using a radioactive isotopic tracer, $^{35}\text{SO}_4^{2-}$. These radioactive measurements, combined with modeled soil water estimates, indicated that 33% of the $^{35}\text{SO}_4^{2-}$ added to the snowpack was retained in the organic soil horizons. Mass balances of $^{34}\text{SO}_4^{2-}$ in our study indicated that the retention or transformation of SO_4^{2-} in the forest floor was similar (38–46%), but slightly higher than the value given by Houle et al. (2004).

There are no similar studies that have used the isotopic mass balance approach to measure soil NO_3^- retention during winter under ambient N loading conditions. Preston et al. (1990), however, directly measured the fate of ^{15}N -labeled NO_3^- as part of a snowpack fertilization experiment in British Columbia, Canada. Despite extremely high experimental N application rates

(100 kg N ha^{-1}), recovery of ^{15}N in organic soil was nevertheless 31% of the total $^{15}\text{NO}_3^-$ -N added to the snowpack, which is only slightly less than the forest floor NO_3^- retention and transformation values we calculated in our study using the mass balance approach (42–51%) under ambient N input levels. Lower N recovery in soil might be expected with high N additions, as the system is pushed toward N saturation. Even under high NO_3^- amendment rates during the winter, however, when there is a marked reduction in N uptake by forest vegetation, the capacity of the forest soil to retain or transform NO_3^- is remarkable.

Bromide recovery in the snow lysimeters was comparable to $^{34}\text{SO}_4^{2-}$ -S and $^{15}\text{NO}_3^-$ -N recoveries, whereas Br^- recovery in the forest floor lysimeters far exceeded $^{34}\text{SO}_4^{2-}$ -S and $^{15}\text{NO}_3^-$ -N recoveries. Even though plastic sheeting confined the area above the lysimeters, there was still a possibility that a portion of the tracers could have leaked through the seams of the barriers. The high recovery rates of Br^- provide evidence that $^{34}\text{SO}_4^{2-}$ -S and $^{15}\text{NO}_3^-$ -N were retained or transformed in the forest floor, and were not lost by leakage. Despite relatively high Br^- recovery, it was <100% in snow and forest floor lysimeters (89 and 83%, respectively). Although Br^- is used widely as a tracer, there is some evidence that suggests Br^- is not entirely conservative and may be affected by geochemical and biogeochemical processes, particularly in organic soils (Gerritse and George, 1988). Hence, some of the Br^- may have been retained in the forest floor. Another possible explanation for the incomplete recovery of Br^- is that samples for chemical analyses and water volume were collected from separate lysimeters because shallow bedrock prevented the installation of water sample collection vessels directly beneath the tipping buckets. Consequently, differences in the timing of snowmelt between lysimeters used to measure water volume and those used to collect samples for chemical analyses could have affected the precise quantification of Br^- recovery.

Chemical concentrations and fluxes of SO_4^{2-} , NO_3^- , and NH_4^+ in throughfall and snowmelt were consistent with isotopic results. There were no significant differences between throughfall and snowmelt for concentrations and fluxes of all ions (Table 1, Fig. 3), supporting the hypothesis that there are no major sinks for these ions in the snowpack. Concentrations of ions within the snowpack were lower than concentrations in throughfall and snowmelt. This finding is well documented and is attributed to ion exclusion and export that occurs during partial melts in winter (Trantor and Jones, 2001). As snow freezes and thaws, ions become more concentrated on snow grain surfaces and are quickly released in an ionic pulse at the initiation of spring snowmelt (Bales et al., 1989). Our tracer results provided additional evidence of the rapid elution of ions from the snowpack. Enhanced melting at the snowpack surface mobilized these ions, producing high concentrations in the first fractions of meltwater. Even though the tracers were applied to the surface of the snow, they quickly passed through the snowpack and organic soil during the initial spring snowmelt event that began on 29 Feb. 2004.

Concentrations of SO_4^{2-} in forest floor leachates were significantly higher than throughfall concentrations (Table 1); however, there were no marked differences in the fluxes of SO_4^{2-} among throughfall, snowmelt, and forest floor leachates (Fig. 3). Concentrations and fluxes of SO_4^{2-} entering and leaving the forest floor were similar (Table 1, Fig. 3). Hence, SO_4^{2-} flux data without isotopic tracers provide no indication of retention in the forest floor, and exemplify how isotopic tracers can provide unique

additional information not obtainable by chemical concentration and flux measurements. The isotopic data provide information on biogeochemical pathways that cannot be detected using only chemical mass balance approaches, especially when the elemental fluxes are small relative to the forest floor and mineral soil pool sizes. Without the benefit of isotopic analysis, some previous studies have concluded that SO_4^{2-} is conservative in the forest floor during the winter (e.g., Rascher et al., 1987). Our study shows that SO_4^{2-} is not conservative in the forest floor; however, the amount of SO_4^{2-} retained or transformed may be nearly equivalent to the amount released, resulting in no net flux of SO_4^{2-} .

There are a number of mechanisms by which SO_4^{2-} can be retained and released in soils during snowmelt. Soil adsorption reactions can rapidly retain SO_4^{2-} ; however, this process is typically of minor importance in the forest floor, since it contains a large amount of organic matter (50–90%, Huntington et al., 1989) and has low contents of Fe and Al oxides and hydroxides, which control the anion adsorption capacity. Additionally, dissolved organic matter is found at higher concentrations in the forest floor than mineral soils and can compete with SO_4^{2-} for ion exchange sites (Mitchell et al., 1992). Biotic retention of SO_4^{2-} may also be important in these soils, although little is known about microbial immobilization of SO_4^{2-} during winter. Sulfate can be transformed into C-bonded S and ester sulfates, which can be subsequently released through S mineralization reactions (Dhamala and Mitchell, 1995; Fitzgerald et al., 1983). Mineralization can produce significant amounts of SO_4^{2-} during winter (e.g., Hazlett et al., 1992) and could have produced enough SO_4^{2-} to balance the amount retained or transformed in the forest floor.

In addition to S retention and release beneath the snowpack during winter, there was also considerable N retention and release, resulting in significant differences in hydrologic fluxes of NH_4^+ and NO_3^- among pools. Fluxes of NH_4^+ -N in the forest floor leachates were markedly higher than fluxes in throughfall and snowmelt, indicating that N mineralization is an important process in these soils during winter, producing substantial amounts of NH_4^+ -N. While in situ measurements of N mineralization would have been lower because of lower soil temperatures, the laboratory measurements provide evidence that there was a viable microbial population capable of producing NH_4^+ -N (Table 2), and previous work at the HBEF has found significant mineralization during winter (Groffman et al., 2001). Mean concentrations of soil extractable NH_4^+ -N for the February and March samples were lower than concentrations for samples obtained in July; however, the values were highly variable for all sampling dates and the differences were not significant. Long-term measurements of extractable NH_4^+ -N obtained for samples from a similar forest type west of Watershed 6 at Hubbard Brook (P.M. Groffman, unpublished data, 2007, www.hubbardbrook.org/data/dataset.php?id=67) indicate that extractable NH_4^+ -N values are highly variable within and among seasons due to the changing balance between production and consumption. These long-term measurements do not show distinct seasonal patterns, and the values measured in our study on the three sampling dates are well within the range of long-term values for corresponding seasons.

Fluxes of NO_3^- -N were markedly lower in forest floor leachates than in throughfall or snowmelt, indicating a sink for NO_3^- -N. Net nitrification values in the forest floor were very low, even for the July sampling date, as was soil extractable NO_3^- -N.

Table 3. Recovery of Br^- , $^{34}\text{SO}_4^{2-}$, and $^{15}\text{NO}_3^-$ in snowmelt and forest floor leachates during the 10 mo following tracer application. Recovery values were calculated using Eq. [2] and are expressed as the percentage recovered of the total added to the snowpack surface.

Pool	Br ⁻ recovery	³⁴ S recovery	¹⁵ N recovery
	%		
Snowmelt	89	90	100
Forest floor leachates	83	54–62	49–58

Nitrification rates have been found to be highly variable in time and space at the HBEF (Bohlen et al., 2000; Groffman et al., 2001; Melillo, 1977; Venterea et al., 2003), and low net nitrification rates indicate either limited production or high consumption of NO_3^- by immobilization, denitrification, or dissimilatory nitrate reduction to ammonia (DNRA).

The results of our study are inconsistent with the expectation of high NO_3^- immobilization by microbes during spring snowmelt. Many studies that have examined the natural abundance O isotope ratios of NO_3^- ($\delta^{18}\text{O}-\text{NO}_3^-$) in ecosystems during spring snowmelt have shown that a large fraction of the snowpack NO_3^- flux is assimilated and subsequently mineralized and nitrified in soils before being released to streams (e.g., Campbell et al., 2006; Kendall et al., 1996; Pardo et al., 2004; Piatek et al., 2005). Microbial immobilization is driven by high C availability (Hart et al., 1994), which is common in HBEF soils (Fahey et al., 2005). Since snow is a thermal buffer between the soil and cold winter air, below-average snowfall during the study period in our study resulted in deeper than average soil frost. A portion of the forest floor remained unfrozen, however, indicating that soil temperatures and free water were adequate for microbial activity (Fig. 4). Despite the potential for microbial N retention during winter, it did not appear important during the snowmelt period. There was no significant difference in microbial biomass $\delta^{15}\text{N}$ between the preapplication (18 Feb. 2004) and post-application spring (4 Mar. 2004) sampling dates (Fig. 6). These data suggest that the NO_3^- released from melting snow was

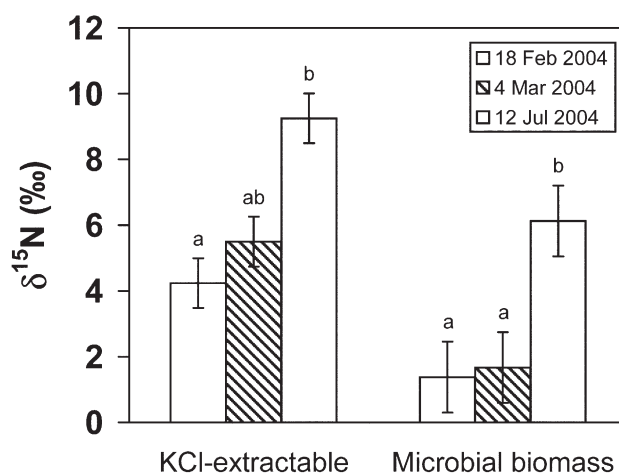

Fig. 6. Potassium chloride-extractable and microbial biomass $\delta^{15}\text{N}$ values measured before the isotopic tracer addition (18 Feb. 2004), during snowmelt (4 Mar. 2004), and in mid-summer (12 July 2004). Different lowercase letters indicate significant differences in KCl-extractable $\delta^{15}\text{N}$ and microbial biomass $\delta^{15}\text{N}$ among the three sampling dates ($\alpha = 0.05$). Error bars indicate the standard error of the group means.

not incorporated into microbial biomass during spring snowmelt even though 87% of the total amount of $^{15}\text{NO}_3^-$ recovered in leachates had passed through the forest floor by the second sampling date (4 Mar. 2004). Differences in soil extractable NO_3^- between the pretreatment and spring sampling dates were also insignificant, suggesting that the bulk of the tracer was not simply held on soil exchange sites during this period. Conclusive evidence for a lack of microbial immobilization during snowmelt would require repeated measurements of microbial biomass $\delta^{15}\text{N}$ to account for the possibility of turnover. The lack of change in microbial biomass $\delta^{15}\text{N}$ indicates that there was no net immobilization; however, this does not eliminate the possibility that there was microbial immobilization followed by turnover.

Interestingly, microbial biomass N pools were significantly enriched in ^{15}N on the summer sampling date (12 July 2004) relative to both the pretreatment and snowmelt (4 Mar. 2004) sampling dates (Fig. 6). It is not possible to determine, however, whether the increase in microbial biomass $\delta^{15}\text{N}$ was due to immobilization of the ^{15}N tracer or to natural variability in microbial biomass $\delta^{15}\text{N}$ values. Mean microbial $\delta^{15}\text{N}$ values were only slightly above the range measured at Hubbard Brook in a similar forest type (-3.8 to 4.1% ; L.M. Christenson, unpublished data, 2007) and these background samples were collected earlier in the year (May) at a different location.

Nitrogen isotope fractionation is typically small in N-limited forest ecosystems (e.g., Campbell et al., 2006). Therefore it is unlikely that fractionation processes markedly influenced N isotope ratios in snowmelt and forest floor leachates. Because $\delta^{15}\text{N}-\text{NO}_3^-$ values of various sources often are indistinct, N isotope ratios are often not useful in determining sources of NO_3^- . The O isotope ratio of NO_3^- ($\delta^{18}\text{O}$) is typically more useful than $\delta^{15}\text{N}$ because $\delta^{18}\text{O}$ values of atmospheric NO_3^- are higher than those of soil microbially produced NO_3^- (Durka et al., 1994). In our study, $\delta^{18}\text{O}-\text{NO}_3^-$ values (Fig. 5e) suggest that the NO_3^- that infiltrated the forest floor during snowmelt was not immobilized by microbes, followed by mineralization and nitrification. From January through March, $\delta^{18}\text{O}-\text{NO}_3^-$ values in forest floor leachates were similar to values of atmospherically derived NO_3^- characterized by high $\delta^{18}\text{O}-\text{NO}_3^-$ (Fig. 5e; Elliott et al., 2005; Kendall, 1998). After spring snowmelt, $\delta^{18}\text{O}-\text{NO}_3^-$ values in the forest floor leachates declined sharply by 45%. The range in $\delta^{18}\text{O}-\text{NO}_3^-$ values in the forest floor leachates during the snow-free period (3.3–25.3‰) was similar to the range in microbially produced NO_3^- reported in the literature (Amberger and Schmidt, 1987; Burns and Kendall, 2002; Mayer et al., 2001; Williard et al., 2001). During nitrification, one of the O atoms used to produce NO_3^- is derived from atmospheric O_2 and two O atoms are taken from ambient soil water with negative $\delta^{18}\text{O}$ values (Andersson and Hooper, 1983; Hollocher, 1984; Hollocher et al., 1981; Kumar et al., 1983). Therefore, the low $\delta^{18}\text{O}-\text{NO}_3^-$ values after spring snowmelt indicate that NO_3^- in the leachates was produced by microbial nitrification. The comparatively high $\delta^{18}\text{O}-\text{NO}_3^-$ values in forest floor leachates during the period of snow cover indicate that the NO_3^- did not cycle through the biomass and came directly from the atmosphere unaltered.

There are several possible explanations in addition to microbial immobilization that could explain how NO_3^- is retained or transformed in the forest floor during winter. Vegetation can substantially lower soil NO_3^- concentrations during the growing season; however, the forest floor material in the lysimeters was isolated

from tree roots and there were very few seedlings and herbaceous plants growing in the lysimeters. Furthermore, roots are not typically active at the HBEF until after snowmelt in late spring (Tierney et al., 2003). Another possible explanation is DNRA, which can be an important sink for NO_3^- in forest soils (Silver et al., 2001). Our analysis of $\delta^{15}\text{N}-\text{NH}_4^+$ on selected soil water samples suggested that the labeled ^{15}N in NO_3^- was not transformed into NH_4^+ by DNRA (Fig. 5c). It is possible, however, that DNRA occurred and the produced NH_4^+ did not leach out of the forest floor. A third possible process for overwinter NO_3^- loss is denitrification, which can lower the availability of NO_3^- during snowmelt in poorly aerated, water-saturated soils (Groffman et al., 1993; Nyborg et al., 1997). Intermittent measurements of denitrification indicate that rates are low at Hubbard Brook during winter (Groffman et al., 2001); however, denitrification may be highly variable, particularly during the snowmelt period. On all sampling dates, the forest floor had a high moisture content (61–72%); therefore, any NO_3^- produced could have been denitrified, resulting in low residual soil NO_3^- . Lastly, the NO_3^- could have been retained abiotically. While this process is poorly understood and its relative importance is unclear, evidence suggests that abiotic NO_3^- retention has the potential to rapidly retain large quantities of N in soil (Davidson et al., 2003).

CONCLUSIONS

Our results indicate that there were no significant transformations of SO_4^{2-} and NO_3^- in the snowpack, but that retention and transformation in the forest floor were significant. Most of the labeled $^{34}\text{S}-\text{SO}_4^{2-}$ and $^{15}\text{N}-\text{NO}_3^-$ added to the snowpack infiltrated the forest floor during spring snowmelt, where 38 to 46% of the SO_4^{2-} and 42 to 51% of the NO_3^- subsequently were retained or transformed. Mass balances of SO_4^{2-} indicated that even though a significant amount of SO_4^{2-} was retained or transformed in the forest floor, a nearly equal amount was released, resulting in no significant difference between forest floor inputs and outputs of SO_4^{2-} . A significant amount of NH_4^+ was produced in the forest floor, indicating that N mineralization can be important, even when soil temperatures are near freezing. By contrast, net nitrification rates were very low and the forest floor was a sink for NO_3^- . Low $^{15}\text{N}-\text{NO}_3^-$ tracer recovery in microbial biomass and high $\delta^{18}\text{O}-\text{NO}_3^-$ values in forest floor leachates suggest that microbes did not immobilize and subsequently mineralize and nitrify snowpack NO_3^- . Other processes such as plant uptake, DNRA, denitrification, and abiotic NO_3^- retention were probably more important in retaining or transforming NO_3^- during snowmelt. Based on our results, we conclude that SO_4^{2-} and NO_3^- are not conservative in organic soil horizons underneath the snowpack, and both biotic and abiotic processes may control the retention and release of these anions during winter. These controls not only influence N and S dynamics during the snowmelt period, but also have effects that are manifested later during the growing season. Hence, understanding N and S cycling during winter is critical to our understanding of longer term N and S trends and responses to ecosystem disturbances such as climate change.

ACKNOWLEDGMENTS

We thank Ian Halm for field assistance, Amey Bailey for providing meteorological data, and Jane Hislop, Sarah Kelly, Anna Keim, Jennifer Plouffe, Lisa Martel, and Sabrina La Fave for sample preparation and laboratory analyses. This manuscript was improved by reviews from

Linda Pardo and Pamela Edwards. The USDA Forest Service, National Science Foundation, and New York State Energy Research Development Authority provided funding for this research. This manuscript is a contribution of the Hubbard Brook Ecosystem Study. The Hubbard Brook Experimental Forest is operated and maintained by the USDA Forest Service, Northern Research Station, Newtown Square, PA.

REFERENCES

- Amberger, A., and H.-L. Schmidt. 1987. Natürliche Isotopengehalte von Nitrat als Indikatoren für dessen Herkunft. *Geochim. Cosmochim. Acta* 51:2699–2705.
- Andersson, K.K., and A.B. Hooper. 1983. O₂ and H₂O and each the source of one O in NO₂ produced from NH₃ by *Nitrosomonas*: ¹⁵N evidence. *FEBS Lett.* 164:236–240.
- Bailey, A.S., J.W. Hornbeck, J.C. Campbell, and C. Eagar. 2003. Hydrometeorological database for Hubbard Brook Experimental Forest: 1955–2000. Gen. Tech. Rep. NE-305. U.S. For. Serv., Northeastern Res. Stn., Newtown Square, PA.
- Bales, R.C., R.E. Davis, and D.A. Stanley. 1989. Ion elution through shallow homogeneous snow. *Water Resour. Res.* 25:1869–1877.
- Blunier, T., G.L. Floch, H.-W. Jacobi, and E. Quansah. 2005. Isotopic view on nitrate loss in Antarctic surface snow. *Geophys. Res. Lett.* 32:L13501, doi:10.1029/2005GL023011.
- Bohlen, P.J., P.M. Groffman, C.T. Driscoll, T.J. Fahey, and T.G. Siccama. 2000. Plant–soil–microbial interactions in a northern hardwood forest. *Ecology* 82:965–978.
- Brooks, P.D., J.M. Stark, B.B. McInteer, and T. Preston. 1989. Diffusion method to prepare soil extracts for automated nitrogen-15 analysis. *Soil Sci. Soc. Am. J.* 53:1707–1711.
- Brooks, P.D., M.W. Williams, and S.K. Schmidt. 1996. Microbial activity under alpine snowpacks, Niwot Ridge, Colorado. *Biogeochemistry* 32:93–113.
- Burns, D.A., and C. Kendall. 2002. Analysis of $\delta^{15}\text{N}$ and $\delta^{18}\text{O}$ to differentiate NO₃⁻ sources in runoff at two watersheds in the Catskill Mountains of New York. *Water Resour. Res.* 38(5):1051, doi:10.1029/2001WR000292.
- Campbell, J.L., M.J. Mitchell, P.M. Groffman, L.M. Christenson, and J.P. Hardy. 2005. Winter in northeastern North America: A critical time for ecological processes. *Front. Ecol. Environ.* 3:314–322.
- Campbell, J.L., M.J. Mitchell, and B. Mayer. 2006. Isotopic assessment of NO₃⁻ and SO₄²⁻ mobility during winter in two adjacent watersheds in the Adirondack Mountains, New York. *J. Geophys. Res.* 111:G04007, doi:10.1029/2006JG000208.
- Dail, D.B., E.A. Davidson, and J. Chorover. 2001. Rapid abiotic transformation of nitrate in an acid forest soil. *Biogeochemistry* 54:131–146.
- Davidson, E.A., J. Chorover, and D.B. Dail. 2003. A mechanism of abiotic immobilization of nitrate in forest ecosystems: The ferrous wheel hypothesis. *Global Change Biol.* 9:228–236.
- Dhamala, B.R., and M.J. Mitchell. 1995. Sulfur speciation, vertical distribution, and seasonal variation in a northern hardwood forest soil, U.S.A. *Can. J. For. Res.* 25:234–243.
- Driscoll, C.T., G.B. Lawrence, A.J. Bulger, T.J. Butler, C.S. Cronan, C. Eagar, K.F. Lambert, G.E. Likens, J.L. Stoddard, and K.C. Weathers. 2001. Acidic deposition in the northeastern United States: Sources and inputs, ecosystem effects, and management strategies. *BioScience* 51:180–198.
- Durka, W., E.D. Schulze, G. Gebauer, and S. Voerkelius. 1994. Effects of forest decline on uptake and leaching of deposited nitrate determined from ¹⁵N and ¹⁸O measurements. *Nature* 372:765–767.
- Elliott, E.M., C. Kendall, K. Harlin, T. Butler, R. Carlton, S. Wankel, E. Boyer, and D. Burns. 2005. What can nitrate isotopes in precipitation tell us about NO_x sources, atmospheric cycling, and source areas? Results from the first national survey in the United States. *EOS Trans. AGU*, 86(52), Fall Meet. Suppl., Abstr. B54A–02.
- Fahey, T.J., G.L. Tierney, R.D. Fitzhugh, G.F. Wilson, and T.G. Siccama. 2005. Soil respiration and soil carbon balance in a northern hardwood forest ecosystem. *Can. J. For. Res.* 35:244–253.
- Fitzgerald, J.W., J.T. Ash, T.C. Strickland, and W.T. Swank. 1983. Formation of organic sulfur in forest soils: A biologically mediated process. *Can. J. For. Res.* 13:1077–1082.
- Fitzhugh, R.D., L.M. Christenson, and G.M. Lovett. 2003. The fate of ¹⁵NO₂⁻ tracer in soils under different tree species of the Catskill Mountains, New York. *Soil Sci. Soc. Am. J.* 67:1257–1265.
- Gerritse, R.G., and R.J. George. 1988. The role of soil organic matter in the geochemical cycling of chloride and bromide. *J. Hydrol.* 101:83–95.
- Giesemann, A., H.-J. Jäger, A.L. Norman, H.R. Krouse, and W.A. Brand. 1994. Online sulphur isotope analysis using an elemental analyzer coupled to a mass spectrometer. *Anal. Chem.* 66:2816–2819.
- Groffman, P.M., C.T. Driscoll, T.J. Fahey, J.P. Hardy, R.D. Fitzhugh, and G.L. Tierney. 2001. Effects of mild winter freezing on soil nitrogen and carbon dynamics in a northern hardwood forest. *Biogeochemistry* 56:191–213.
- Groffman, P.M., D.R. Zak, S. Christensen, A. Mosier, and J.M. Tiedje. 1993. Early spring nitrogen dynamics in a temperate forest landscape. *Ecology* 74:1579–1585.
- Hart, S.C., G.E. Nason, D.D. Myrold, and D.A. Perry. 1994. Dynamics of gross nitrogen transformations in an old-growth forest: The carbon connection. *Ecology* 75:880–891.
- Hastings, M.G., E.J. Steig, and D.M. Sigman. 2004. Seasonal variations in N and O isotopes of nitrate in snow at Summit, Greenland: Implications for the study of nitrate in snow and ice cores. *J. Geophys. Res.* 109: D20306, doi:10.1029/2004JD004991.
- Hazlett, P.W., M.C. English, and N.W. Foster. 1992. Ion enrichment of snowmelt water by processes within a podzolic soil. *J. Environ. Qual.* 21:102–109.
- Hollocher, T.C. 1984. Source of the oxygen atoms of nitrate in the oxidation of nitrite by *Nitrobacter agilis* and evidence against a P–O–N anhydride mechanism in oxidative phosphorylation. *Arch. Biochem. Biophys.* 233:721–727.
- Hollocher, T.C., M.E. Tate, and D.J.D. Nicholas. 1981. Oxidation of ammonia by *Nitrosomonas europaea*: Definitive ¹⁸O-tracer evidence that hydroxylamine formation involves a monooxygenase. *J. Biol. Chem.* 256:10834–10836.
- Houle, D., R. Carignan, and J. Roberge. 2004. The transit of ³⁵SO₄²⁻ and ³H₂O added in situ to soil in a boreal coniferous forest. *Water Air Soil Pollut.* 4:501–516.
- Huntington, T.G., C.E. Johnson, A.H. Johnson, T.G. Siccama, and D.F. Ryan. 1989. Carbon, organic matter, and bulk density relationships in a forested Spodosol. *Soil Sci.* 148:380–386.
- Johnson, D.W., and M.J. Mitchell. 1998. Responses of forest ecosystems to changing sulfur inputs. p. 219–262. *In* D. Maynard (ed.) *Sulfur in the environment*. Marcel Dekker, New York.
- Judd, K., G.E. Likens, and P.M. Groffman. 2007. High nitrate retention during winter in soils of the Hubbard Brook Experimental Forest. *Ecosystems* 10:217–225.
- Kahl, J.S., J.L. Stoddard, R. Haeuber, S.G. Paulsen, R.B. Birnbaum, F.A. Deviney, et al. 2004. Have U.S. surface waters responded to the 1990 Clean Air Act amendments? *Environ. Sci. Technol.* 38:484–490.
- Kendall, C. 1998. Tracing nitrogen sources and cycling in catchments. p. 519–576. *In* C. Kendall and J.J. McDonnell (ed.) *Isotope tracers in catchment hydrology*. Elsevier Sci., New York.
- Kendall, C., S.R. Silva, C.C.Y. Chang, D.A. Burns, D.H. Campbell, and J.B. Shanley. 1996. Use of the $\delta^{18}\text{O}$ and $\delta^{15}\text{N}$ of nitrate to determine sources of nitrate in early spring runoff in forested catchments. p. 167–176. *In* *Isotopes in Water Resources Management: Int. Atomic Energy Agency Symp.*, Vienna, Austria. 20–24 Mar. 1995. IAEA, Vienna.
- Kumar, S., D.J.D. Nicholas, and E.H. Williams. 1983. Definitive ¹⁵N NMR evidence that water serves as a source of ‘O’ during nitrite oxidation by *Nitrobacter agilis*. *FEBS Lett.* 152:71–74.
- Likens, G.E., and F.H. Bormann. 1995. *Biogeochemistry of a forested ecosystem*. 2nd ed. Springer-Verlag, New York.
- Mayer, B., S.M. Bollwerk, T. Mansfeldt, B. Hütter, and J. Veizer. 2001. The oxygen isotope composition of nitrate generated by nitrification in acid forest floors. *Geochim. Cosmochim. Acta* 65:2743–2756.
- Mayer, B., K.H. Feger, A. Giesemann, and H.J. Jäger. 1995. Interpretation of sulfur cycling in two catchments in the Black Forest (Germany) using stable sulfur and oxygen isotope data. *Biogeochemistry* 30:31–58.
- Melillo, J.M. 1977. Mineralization of nitrogen in northern forest ecosystems. Ph.D. diss. Yale Univ., New Haven, CT (Diss. Abstr. 7728153).
- Mitchell, M.J., M.B. David, and R.B. Harrison. 1992. Sulfur dynamics of forest ecosystems. p. 215–254. *In* R.W. Howarth et al. (ed.) *Sulfur cycling on the continents*. SCOPE 48. John Wiley & Sons, New York.
- Monson, R.K., D.L. Lipson, S.P. Burns, A.A. Turnipseed, A.C. Delany, M.W. Williams, and S.K. Schmidt. 2006. Winter forest soil respiration

- controlled by climate and microbial community composition. *Nature* 439:711–714.
- Nyborg, M., J.W. Laidlaw, E.D. Solberg, and S.S. Malhi. 1997. Denitrification and nitrous oxide emissions from a black chernozemic soil during spring thaw in Alberta. *Can. J. Soil Sci.* 77:153–160.
- Pardo, L.H., C. Kendall, J. Pett-Ridge, and C.C.Y. Chang. 2004. Evaluating the source of streamwater nitrate using $\delta^{15}\text{N}$ and $\delta^{18}\text{O}$ in nitrate in two watersheds in New Hampshire, USA. *Hydrol. Processes* 18:2699–2712.
- Paul, E., D. Harris, M.J. Klug, and R.W. Ruess. 1999. The determination of microbial biomass. p. 291–317. *In* G.P. Robertson et al. (ed.) *Standard soil methods for long-term ecological research*. Oxford Univ. Press, New York.
- Piatek, K.B., M.J. Mitchell, S.R. Silva, and C. Kendall. 2005. Sources of nitrate in snowmelt discharge: Evidence from water chemistry and stable isotopes of nitrate. *Water Air Soil Pollut.* 165:13–35.
- Preston, C.M., V.G. Marshall, K. McCullogh, and D.J. Mead. 1990. Fate of ^{15}N -labelled fertilizer applied on snow at two forest sites in British Columbia. *Can. J. Forest Res.* 20:1583–1592.
- Rascher, C.M., C.T. Driscoll, and N.E. Peters. 1987. Concentration and flux of solutes from snow and forest floor during snowmelt in the west-central Adirondack region of New York. *Biogeochemistry* 3:209–224.
- Ricard, J.A., W. Tobiasson, and A. Greatorex. 1976. The field assembled frost gage. CRREL Tech. Note. U.S. Army Cold Reg. Res. and Eng. Lab, Hanover, NH.
- Robertson, G.P., D. Wedin, P.M. Groffman, J.M. Blair, E.A. Holland, K.J. Nadelhoffer, and D. Harris. 1999. Soil carbon and nitrogen availability: Nitrogen mineralization, nitrification, and soil respiration potentials. p. 258–271. *In* G.P. Robertson et al. (ed.) *Standard soil methods for long-term ecological research*. Oxford Univ. Press, New York.
- Schadt, C.W., A.P. Martin, D.A. Lipson, and S.K. Schmidt. 2003. Seasonal dynamics of previously unknown fungal lineages in tundra soils. *Science* 301:1359–1361.
- Schaefer, D.A., and C.T. Driscoll. 1993. Identifying sources of snowmelt acidification with a watershed mixing model. *Water Air Soil Pollut.* 67:345–365.
- Schmidt, S.K., and D.A. Lipson. 2004. Microbial growth under the snow: Implications for nutrient and allelochemical availability in temperate soils. *Plant Soil* 259:1–7.
- Sebilo, M., B. Mayer, M. Grably, D. Billiou, and A. Mariotti. 2004. The use of the 'ammonium diffusion' method for $\delta^{15}\text{N-NH}_4^+$ and $\delta^{15}\text{N-NO}_3^-$ measurements: Comparison with other techniques. *Environ. Chem.* 1:1–5.
- Shanley, J.B., B. Mayer, R.L. Michel, M.J. Mitchell, S.W. Bailey, and C. Kendall. 2005. Tracing sources of streamwater sulfate during snowmelt using S and O isotope ratios of sulfate and ^{35}S activity. *Biogeochemistry* 76:161–185.
- Silva, S.R., C. Kendall, D.H. Wilkison, A.C. Ziegler, C.C.Y. Chang, and R.J. Avanzino. 2000. A new method for collection of nitrate from fresh water and the analysis of nitrogen and oxygen isotope ratios. *J. Hydrol.* 228:22–36.
- Silver, W.L., D.J. Herman, and M.K. Firestone. 2001. Dissimilatory nitrate reduction to ammonium in upland tropical forest soils. *Ecology* 82:2410–2416.
- Sommerfeld, R.A., A.R. Mosier, and R.C. Musselman. 1993. CO_2 , CH_4 , and N_2O flux through a Wyoming snowpack and implications for global budgets. *Nature* 361:140–142.
- Tierney, G.L., T.J. Fahey, P.M. Groffman, J.P. Hardy, R.D. Fitzhugh, C.T. Driscoll, and J.B. Yavitt. 2003. Environmental control of fine root dynamics in a northern hardwood forest. *Global Change Biol.* 9:670–679.
- Trantor, M., and H.G. Jones. 2001. The chemistry of snow: Processes and nutrient cycling. p. 127–167. *In* H.G. Jones et al. (ed.) *Snow ecology: An interdisciplinary examination of snow-covered ecosystems*. Cambridge Univ. Press, New York.
- Venterea, R.T., G.M. Lovett, P.M. Groffman, and P.A. Schwarz. 2003. Landscape patterns of soil nitrate production in a northern hardwood-conifer forest. *Soil Sci. Soc. Am. J.* 67:527–539.
- Wigington, P.J., D.R. DeWalle, P.S. Murdoch, W.A. Kretser, H.A. Simonin, J. Van Sickle, and J.P. Baker. 1996. Episodic acidification of small streams in the northeastern United States: Ionic controls of episodes. *Ecol. Applic.* 6:389–407.
- Williams, M.W., P.D. Brooks, A. Mosier, and K.A. Tonnessen. 1996. Mineral nitrogen transformations in and under seasonal snow in a high-elevation catchment in the Rocky Mountains, United States. *Water Resour. Res.* 32:3161–3171.
- Williard, K.W.J., D.R. DeWalle, P.J. Edwards, and W.E. Sharpe. 2001. ^{18}O isotopic separation of stream nitrate sources in mid-Appalachian forested watersheds. *J. Hydrol.* 252:174–188.